

API FORGED STEEL GATE VALVE

VYDC 800 / VYDC 900
VYDC 1500 / VYDC 2500

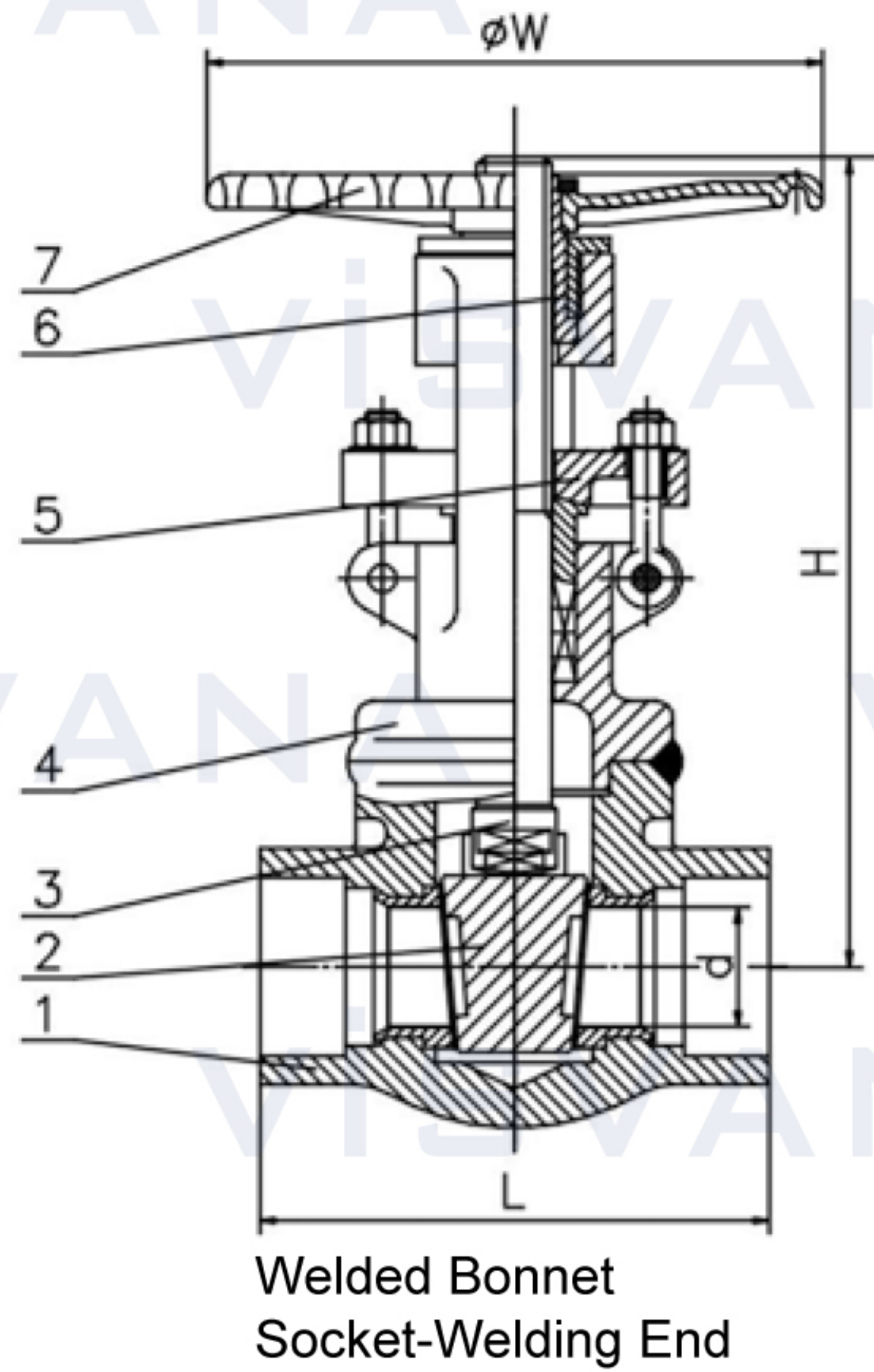
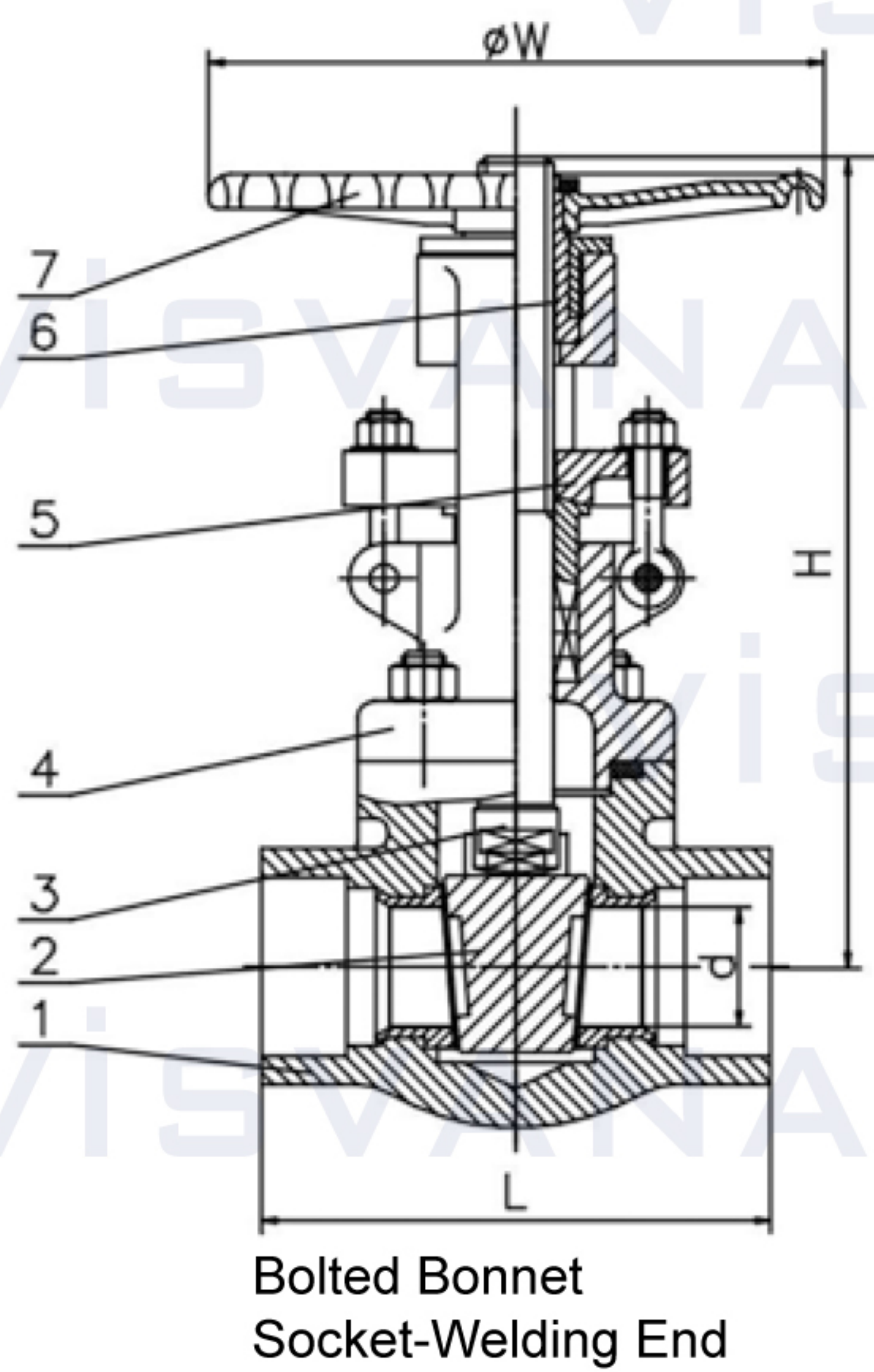

Standards

Design and Manufacture	API 602	Part Name		Material	
Inspection and Test	API598	1	Body	ASTM A105	ASTM A182F304 / ASTM A182F316
Socket-weld dimension	ASME B16.11	2	Disc	ASTM A105	ASTM A182F304 / ASTM A182F316
End threads dimension	ASME B1.20.1	3	Stem	ASTM A182F6	ASTM A182F304 / ASTM A182F316
Pressure-temperature ratings	ASME B16.34	4	Bonnet	ASTM A105	ASTM A182F304 / ASTM A182F316
		5	Gland Flange	ASTM A105	ASTM A182F304 / ASTM A182F316
		6	Stem Nut	ASTM A276410	
		7	Handwheel	ASTM A197	

Class 150 & Class 1500 Forged steel Gate Valve

Class	Size		Dimensions (mm)				NPT	Weight (Kg)
	NPS	DN	L	d	H	W		
150 - 800	1/2"	15	79	13	153	100	1/2"	2.0
	3/4"	20	92	13	153	100	3/4"	2,2
	1"	25	111	18	185	125	1"	3,6
	1 1/4"	32	120	29	222	160	1 1/4"	6,2
	1 1/2"	40	120	29	240	160	1 1/2"	6,2
	2"	50	140	36,5	279	180	2"	9,7
900 - 1500	1/2"	15	92	13	181	125	1/2"	3,5
	3/4"	20	111	13	181	125	3/4"	4.0
	1"	25	120	18	218	160	1"	6.0
	1 1/4"	32	120	24	237	160	1 1/4"	7.0
	1 1/2"	40	140	29	274	180	1 1/2"	10,8
	2"	50	160	36,8	319	200	2"	15,5
2500	1/2"	15	150	14	284	160	1/2"	10.0
	3/4"	20	150	14	284	160	3/4"	12,8
	1"	25	170	19	327	200	1"	22,5
	1 1/4"	32	200	25	374	250	1 1/4"	31,7
	1 1/2"	40	200	28	377	250	1 1/2"	33.0
	2"	50	250	35	434	300	2"	38.0