

Floating ball valve

Bolted bonnet, Two-pieces Body, floating Ball
 Full or Reduced bore, Anti Blowout stem.
 Fire safe and Anti Static.
 Stainless steel ball
 ASTM A216 WCB, A351 CF8, A351 CF8M,
 A351 CF3, A351 CF3M, A351 CN7M

Standards compliance

Design and Manufacture: API 608, API6D, BS5351
 Face to face(end to end):ANSI B 16.10, API6D, JIS B 2002
 Flanged connection: ANSI B16.5, JISB2212-2214
 Fire-safe:API607, API6 FA
 Butt welded end:ANSI B16.25
 Test and inspection:API598, API6D, JIS B2003

Parts and material list

Parts No	Parts Name	Material				
		WCB/13Cr	WCB/304	WCB/316	WCB/304	CF8M/316
1	Body	ASTM A216 WCB	ASTM A216 WCB	ASTM A216 WCB	ASTM A351 CF8	ASTM A351 CF8M
10	Packing	PTFE	PTFE	PTFE	PTFE	PTFE
11	Gland flange	ASTM A216 WCB	ASTM A216 WCB	ASTM A216 WCB	ASTM A351 CF8	ASTM A351 CF8M
12	Stop collar	Carbon steel	Carbon steel	Carbon steel	Carbon steel	Carbon steel
13	Lever	Carbon steel	Carbon steel	Carbon steel	Carbon steel	Carbon steel
8	Thrust washer	PTFE	PTFE	PTFE	PTFE	PTFE
7	Stem	ASTM A182 F6a	ASTM A182 F304	ASTM A182 F316	ASTM A182 F304	ASTM A182 F316
6	Ball	ASTM A182 F6a	ASTM A182 F304	ASTM A182 F316	ASTM A182 F304	ASTM A182 F316
5	Seat	Reinforced PTFE	Reinforced PTFE	Reinforced PTFE	Reinforced PTFE	Reinforced PTFE
9	Gasket	PTFE	PTFE	PTFE	PTFE	PTFE
2	Body nut	ASTM A194 2H	ASTM A194 2H	ASTM A194 2H	ASTM A194 8	ASTM A194 8M
3	Body bolting	ASTM A193 B7	ASTM A193 B7	ASTM A193 B7	ASTM A193 B8	ASTM A193 B8M
4	Closure	ASTM A216 WCB	ASTM A216 WCB	ASTM A216 WCB	ASTM A351 CF8	ASTM A351 CF8M

Noted: the chart above only lists out some common composition of steel ball valve parts, we may provide other different parts material composition according to the customer's request or the actual valve working condition.

API FLOATING BALL VALVE

VFTBV-C150 / VFTBV-C300
 VFTBV-C600 / VFTBV-C900
 VFTBV-C1500

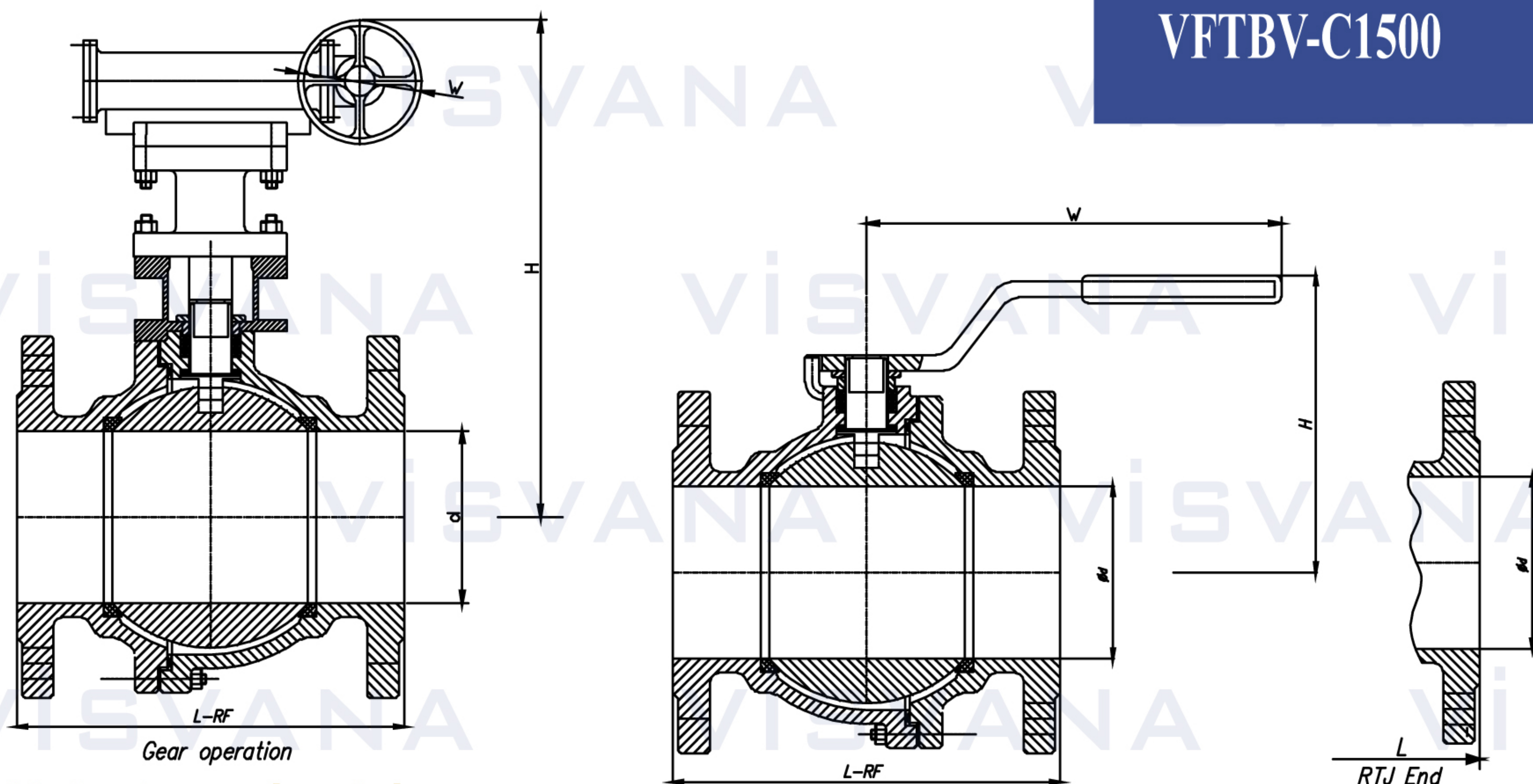

Main size and weight

Class	Size		Dimensions (mm)							Weight (Kg)	
	DN	NPS	L			Hand wheel	Gear box	Hand wheel	Gear box	Hand wheel	Gear box
			d	RF	RTJ						
150 10K	15	½	13	108	119	140		85		3	
	20	¾	19	117	130	140		90		3,2	
	25	1	25	127	140	150		99		3,5	
	32	1 1/4	32	140	153	180		105		5	
	40	1 1/2	38	165	178	300		165		6	
	50	2	49	178	191	350		140		11	
	65	2 1/2	62	190	203	350		180		13,5	
	80	3	75	203	216	500		235		19	
	100	4	100	229	242	500	305	250	380	29	53
	125	5	127	356	369	800	305	280	405	49	79
	150	6	150	394	407	800	305	310	460	65	102
200	8	201	457	470	1000	305	350	550	115	185	
250	10	252	533	546		400		706		280	
300 20K	15	½	13	140	151	140		85		3	
	20	¾	19	152	165	140		90		5	
	25	1	25	165	178	150		99		6	
	32	1 1/4	32	178	191	180		105		8	
	40	1 1/2	38	190	203	200		126		11	
	50	2	49	216	232	250		142		16	
	65	2 1/2	62	241	257	300		165		23	
	80	3	74	283	299	350		178		30	52
	100	4	100	305	321	500	305	230	330	47	76
	125	5	127	381	397	800	305	280	380	74	124
150	6	150	403	419	800	305	310	420	107	163	
200	8	201	502	518	1000	305	350	480	153	267	
600	15	½	13	165	164	140		79	560	5	
	20	¾	19	190	190	140		83		7	
	25	1	25	216	216	200		114		9	
	32	1 1/4	32	229	229	200		120		13	
	40	1 1/2	38	241	241	250		125		17	
	50	2	49	292	295	300		156		25	
	65	2 1/2	62	330	333	350		172		42	
	80	3	74	356	359	500	305	220	370	56	76
100	4	100	432	435	650	305	250	400	85	123	
900	15	½	13	216	216	150		98		9	
	20	¾	19	229	229	150		105		13	
	25	1	25	254	254	200		110		16	
	32	1 1/4	32	279	279	250		120		24	
	40	1 1/2	38	305	305	250		125		31	
	50	2	49	368	371	350		160		45	
1500	15	½	13	216	216	182		98		10	
	20	¾	19	229	229	250		125		14	
	25	1	25	254	254	250		130		17	
	32	1 1/4	32	279	279	300		155		25	
	40	1 1/2	38	305	305	350		180		33	
	50	2	49	368	371	450		225		48	

Noted: We may provide other different actuators according to the customer's request, such as pneumatic, electric, hydraulic actuators, the details of them according to the actual valve working condition.