

API GLOBE VALVE

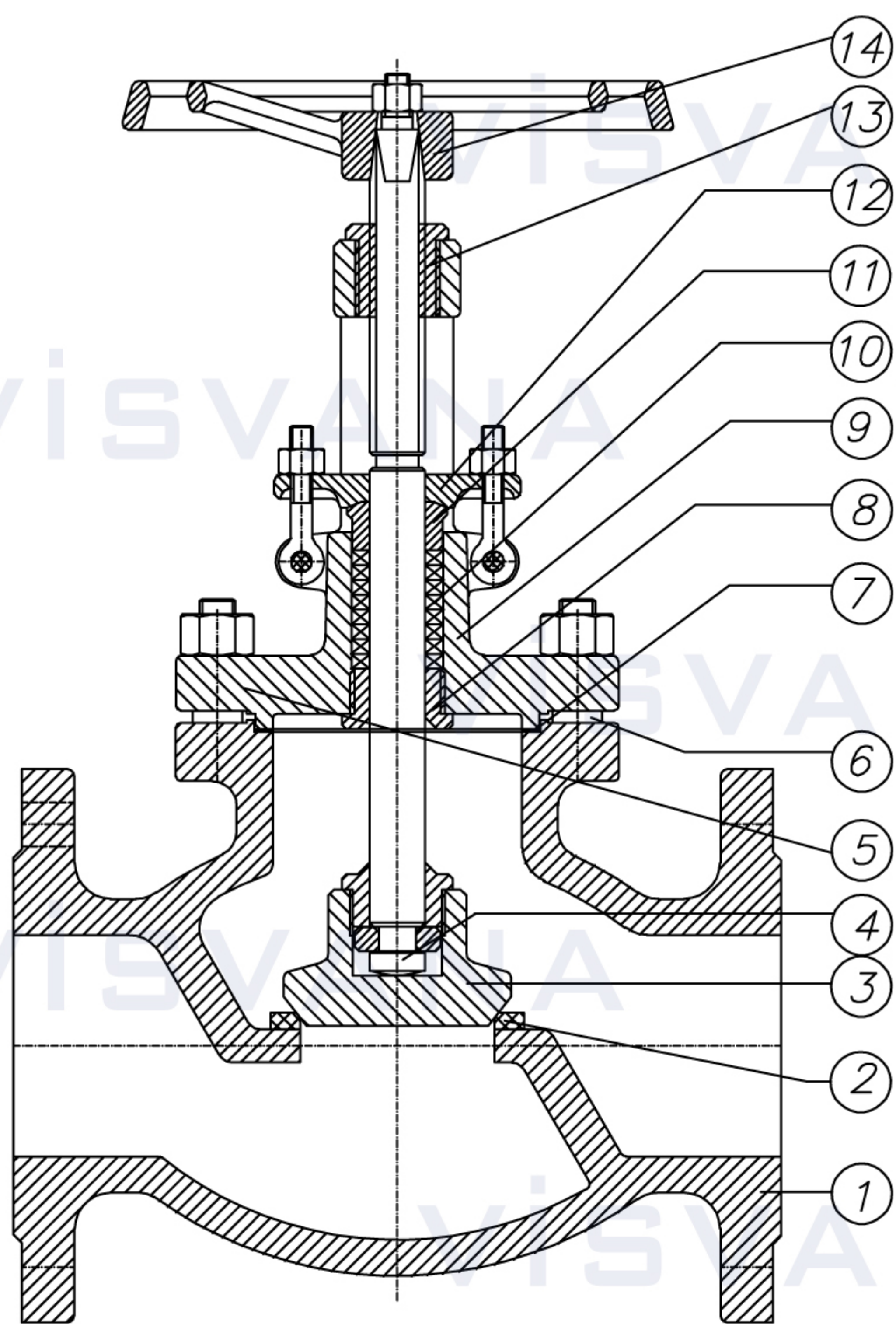

STANDARD MATERIAL TO API600

Trim Code	Seat Ring Surface Part No.2	Wedge Surface Part No.3	Stem Part No.4	Backseat Part No.8
1	F6	F6	F6	F6
2	F304	F304	F304	F304
5	Stellite	Stellite	F6	F6
8	Stellite	F6	F6	F6
9	Monel	Monel	Monel	Monel
10	F316	F316	F316	F316
13	Alloy 20	Alloy 20	Alloy 2	Alloy 20

Standards

Design and Manufacture	BS 1873 and ASME B16.34
Inspection and Test	API598
End Flange dimension	ASME B16.5
BW end dimension	ASME B16.25
Socket-weld dimension	ASME B16.11
Face to face	ASME B16.10
Pressure-temperature ratings	ASME B16.34

Part and material list

Parts name		Carbon steel to ASTM		Alloy Steel to ASTM				Stainless Steel to ASTM			
1	Body	A216WCB	A352LCB	A217WC1	A217WC6	A217WC9	A217WC5	A351CF8	A351CF8M	A351CF3	A351CF3M
9	Bonnet	A216WCB	A352LCB	A217WC1	A217WC6	A217WC9	A217WC5	A351CF8	A351CF8M	A351CF3	A351CF3M
6	Bolt	A193 B7	A320 L7	A193 B7	A193 B16	A193 B16	A193 B16	A193 B8	A193 B8	A193 B8	A193 B8
5	Nut	A194 2H	A194 2H	A194 2H	A194 4	A194 4	A194 4	A194 8	A194 8	A194 8	A194 8
11	Gland	A182 F6a	A182 F6a	A182 F6a	A182 F6a	A182 F6a	A182 F6a	304	316	304L	316L
12	Gland Flange	A216WCB	A352LCB	A217WC1	A217WC6	A217WC9	A217WC5	A351CF8	A351CF8M	A351CF3	A351CF3M
3	Disc	A216WCB	A352LCB	A217WC1	A217WC6	A217WC9	A217WC5	A351CF8	A351CF8M	A351CF3	A351CF3M
7	Gasket	SS Spiral Wound W/graphite or SS Spiral Wound W/PTFE, or Reinforced PTFE									
10	Packing	Braided graphite or Die-formed graphite ring or PTFE									
13	Stem Nut	Copper alloy or A439 D2									
14	Hand Wheel	Ductile iron or Carbon steel									

Noted: The chart above only lists out some common composition of steel globe valve parts. We may provide other different parts material composition according to the customer's request or the actual valve working condition.

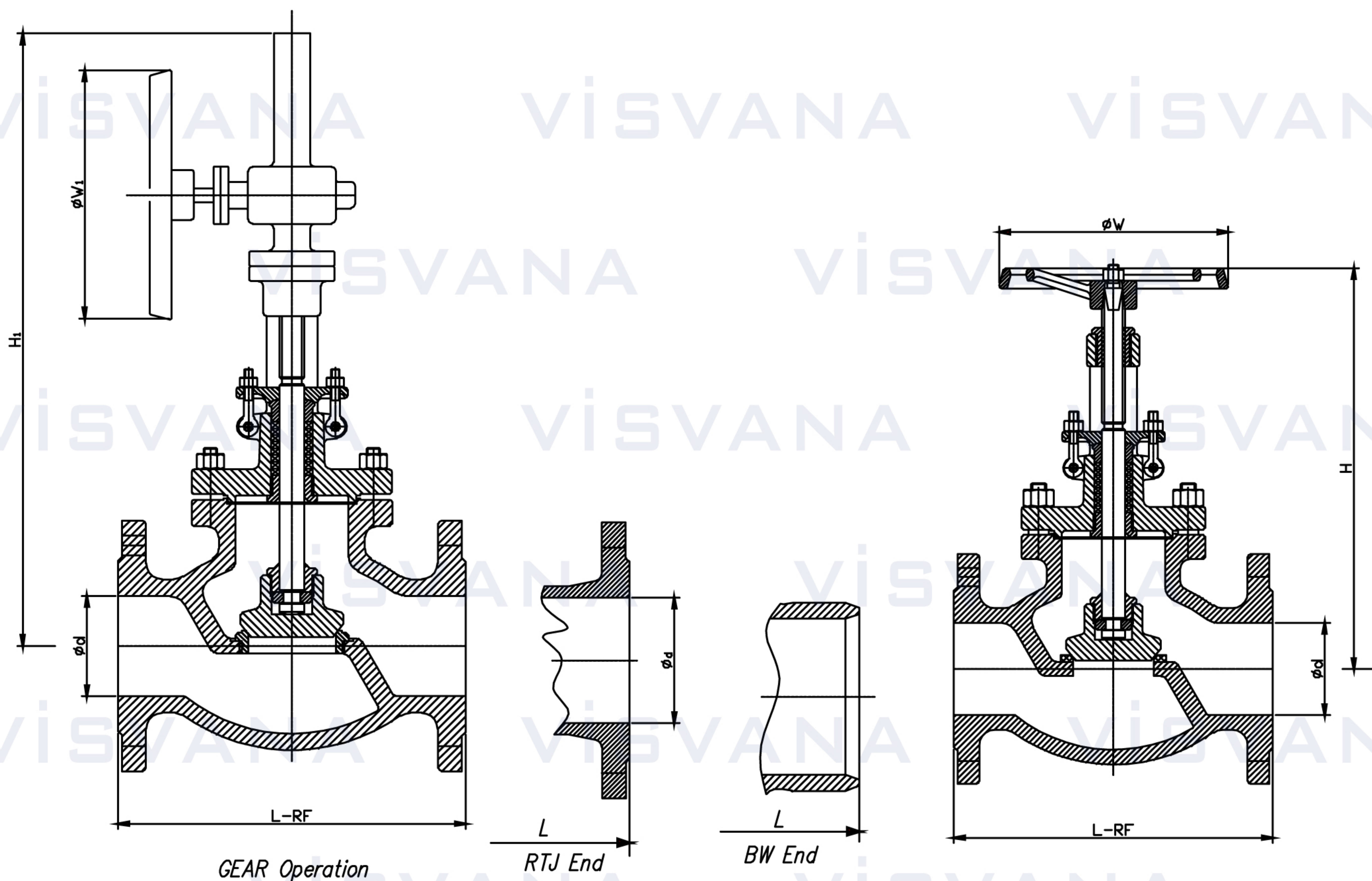

Class 300 & JIS 20K Cast Steel Globe Valve

Class	Size		Dimensions (mm)								Weight (Kg)	
	NPS	DN	L			d	H	H1	W	W1	H.W	G.O
			RF	RTJ	BW							
300	1/2	15	152	164	152	13	184		120		5	
	3/4	20	178	191	178	19	226		160		6.5	
	1	25	203	216	203	25	233		160		9	
	1 1/4	32	216	229	216	32	253		160		12	
	1 1/2	40	229	241	229	38	273		160		16	
	2	50	267	283	267	51	346		200		29	
	2 1/2	65	292	308	292	64	390		250		44	
	3	80	318	333	318	76	403		280		59	
	4	100	356	371	356	102	474		350		87	
	5	125	400	416	400	127	540		350		181	
	6	150	444	460	444	152	635	690	450	310	162	177
	8	200	559	575	559	203	870	950	550	460	281	389
	10	250	622	638	622	254	950	990	600	460	355	409
	12	300	711	727	711	305	1030	1155	700	460	575	635
	14	350	838			336		1155		600		880
	16	400	864			387		1325		600		1300
18	450	977			431		1473		720		1600	
20	500	1016			482		1574		720		2100	

Noted: We may provide other different actuators according to the customer's request, such as pneumatic, electric, hydraulic actuators, the details of them according to the actual valve working condition.