

# API GLOBE VALVE

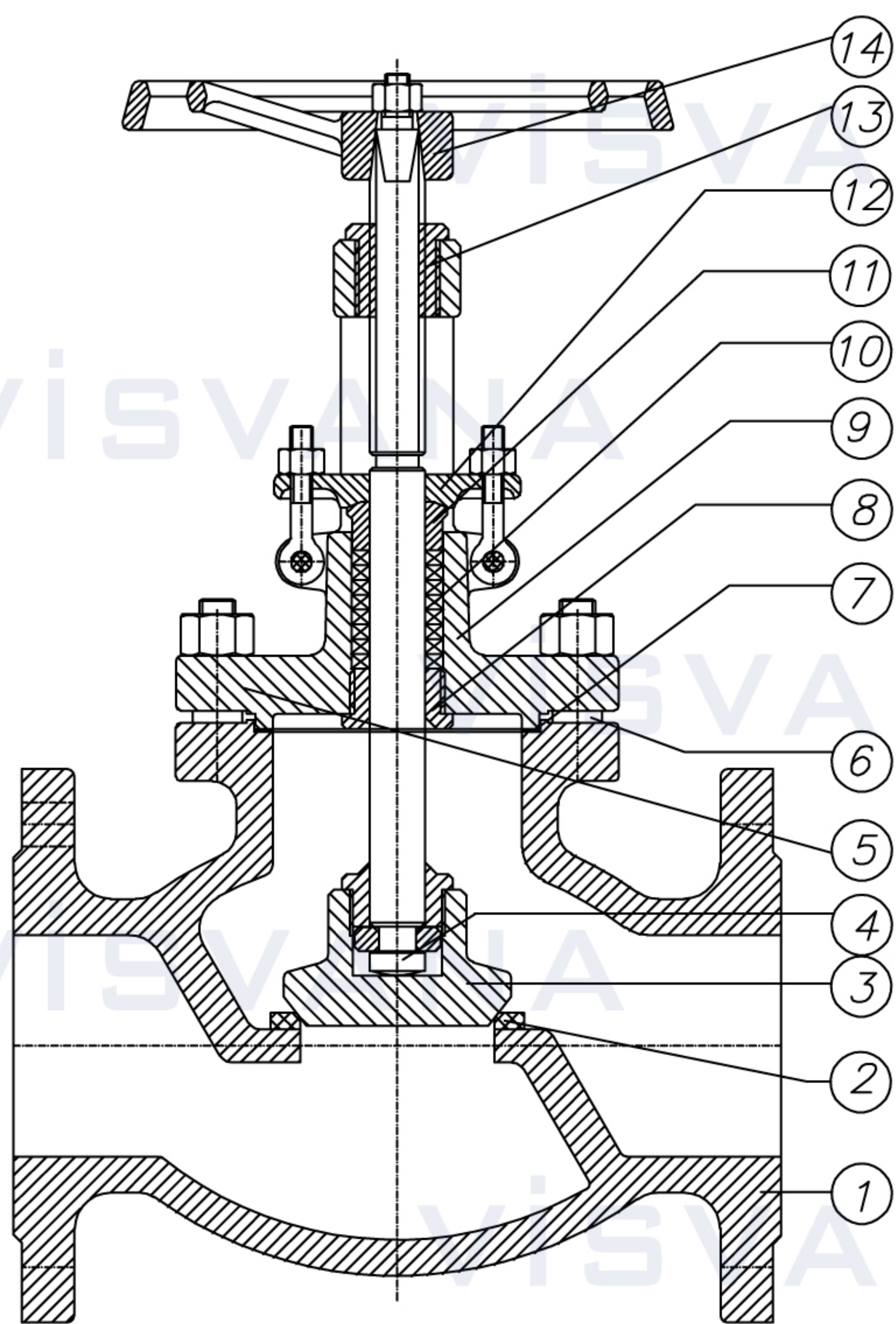

## STANDARD MATERIAL TO API600

Trim Code	Seat Ring Surface Part No.2	Wedge Surface Part No.3	Stem Part No.4	Backseat Part No.8
1	F6	F6	F6	F6
2	F304	F304	F304	F304
5	Stellite	Stellite	F6	F6
8	Stellite	F6	F6	F6
9	Monel	Monel	Monel	Monel
10	F316	F316	F316	F316
13	Alloy 20	Alloy 20	Alloy 2	Alloy 20

## Standards

Design and Manufacture	BS 1873 and ASME B16.34
Inspection and Test	API598
End Flange dimension	ASME B16.5
BW end dimension	ASME B16.25
Socket-weld dimension	ASME B16.11
Face to face	ASME B16.10
Pressure-temperature ratings	ASME B16.34

## Part and material list

Parts name		Carbon steel to ASTM		Alloy Steel to ASTM				Stainless Steel to ASTM			
1	Body	A216WCB	A352LCB	A217WC1	A217WC6	A217WC9	A217WC5	A351CF8	A351CF8M	A351CF3	A351CF3M
9	Bonnet	A216WCB	A352LCB	A217WC1	A217WC6	A217WC9	A217WC5	A351CF8	A351CF8M	A351CF3	A351CF3M
6	Bolt	A193 B7	A320 L7	A193 B7	A193 B16	A193 B16	A193 B16	A193 B8	A193 B8	A193 B8	A193 B8
5	Nut	A194 2H	A194 2H	A194 2H	A194 4	A194 4	A194 4	A194 8	A194 8	A194 8	A194 8
11	Gland	A182 F6a	A182 F6a	A182 F6a	A182 F6a	A182 F6a	A182 F6a	304	316	304L	316L
12	Gland Flange	A216WCB	A352LCB	A217WC1	A217WC6	A217WC9	A217WC5	A351CF8	A351CF8M	A351CF3	A351CF3M
3	Disc	A216WCB	A352LCB	A217WC1	A217WC6	A217WC9	A217WC5	A351CF8	A351CF8M	A351CF3	A351CF3M
7	Gasket	SS Spiral Wound W/graphite or SS Spiral Wound W/PTFE, or Reinforced PTFE									
10	Packing	Braided graphite or Die-formed graphite ring or PTFE									
13	Stem Nut	Copper alloy or A439 D2									
14	Hand Wheel	Ductile iron or Carbon steel									

Noted: The chart above only lists out some common composition of steel globe valve parts. We may provide other different parts material composition according to the customer's request or the actual valve working condition.

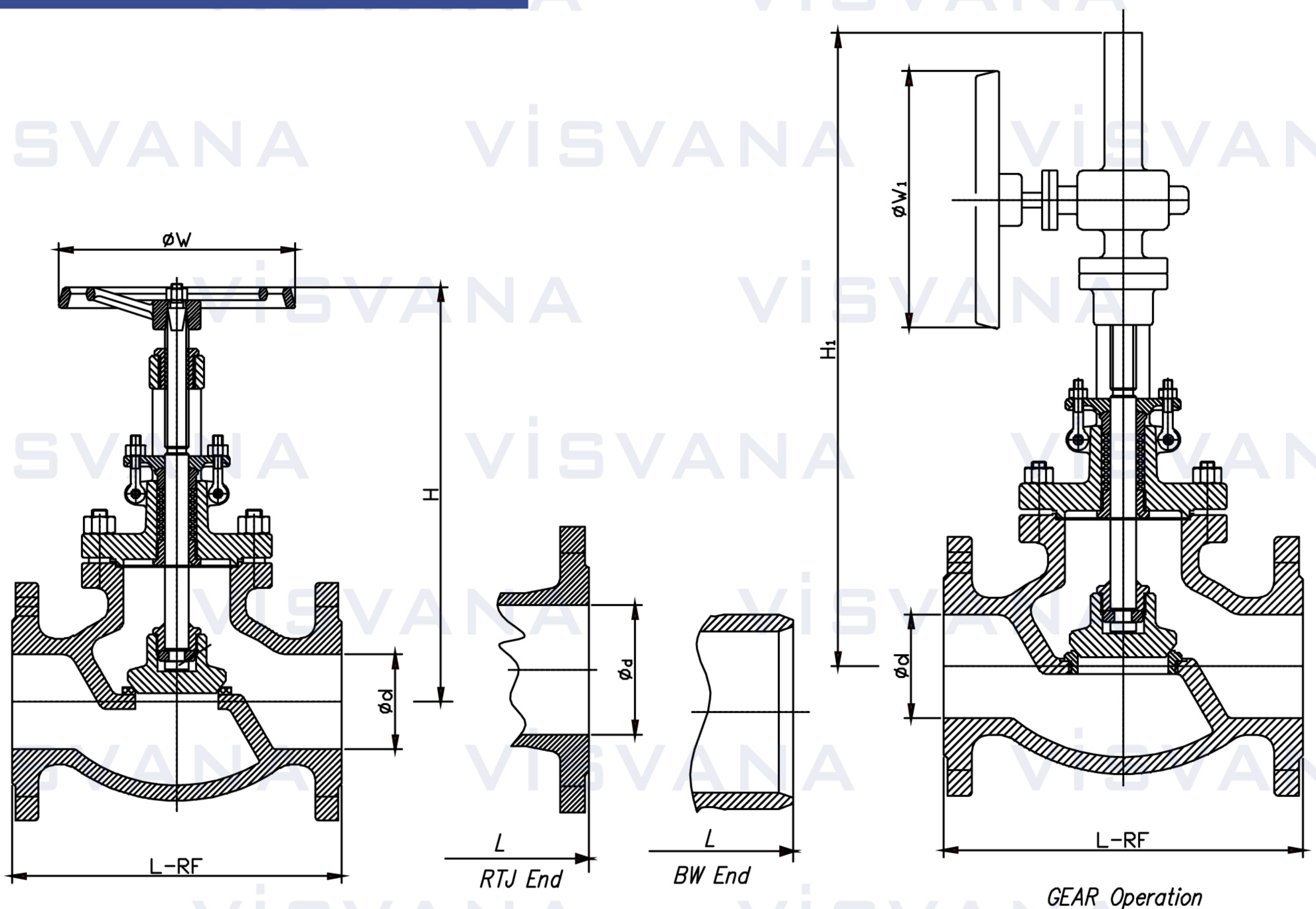

### Class 150 & JIS 10K Gate Valve

Class	Size		Dimensions (mm)								Weight (Kg)	
	NPS	DN	L			d	H	H1	W	W1	H.W	G.O
			RF	RTJ	BW							
150	1/2	15	108	119	108	13	185		100		4	
	3/4	20	117	130	117	19	190		100		4.5	
	1	25	127	140	127	25	211		100		5.5	
	1 1/4	32	140	152	140	32	220		135		8.5	
	1 1/2	40	165	178	165	38	240		135		12	
	2	50	203	216	203	51	328		200		18	
	2 1/2	65	216	229	216	64	360		250		26	
	3	80	241	254	241	76	373		280		43	
	4	100	292	305	292	102	400		300		54	
	5	125	356	369	356	127	435		350		71	
	6	150	406	419	406	152	528	556	350	310	95	114
	8	200	495	508	495	203	680	658	400	310	160	158
	10	250	622	635	622	254	775	805	450	460	299	259
	12	300	698	711	698	305	880	955	500	460	373	378
	14"	350	787	800	787	337		1100		460		640
	16"	400	914	927	914	387		1175		460		920
20"	500	978	991	978	488		1450		600		1650	
24"	600	1295	1308	1295	590		1690		600		2200	

Noted: We may provide other different actuators according to the customer's request, such as pneumatisch, electric, hydraulic actuators, the details of them according to the actual valve working condition.