

API FORGED STEEL CHECK VALVE

VDCS-C800 / VDCS-C900
VDCS-C1500 / VDCS-C2500

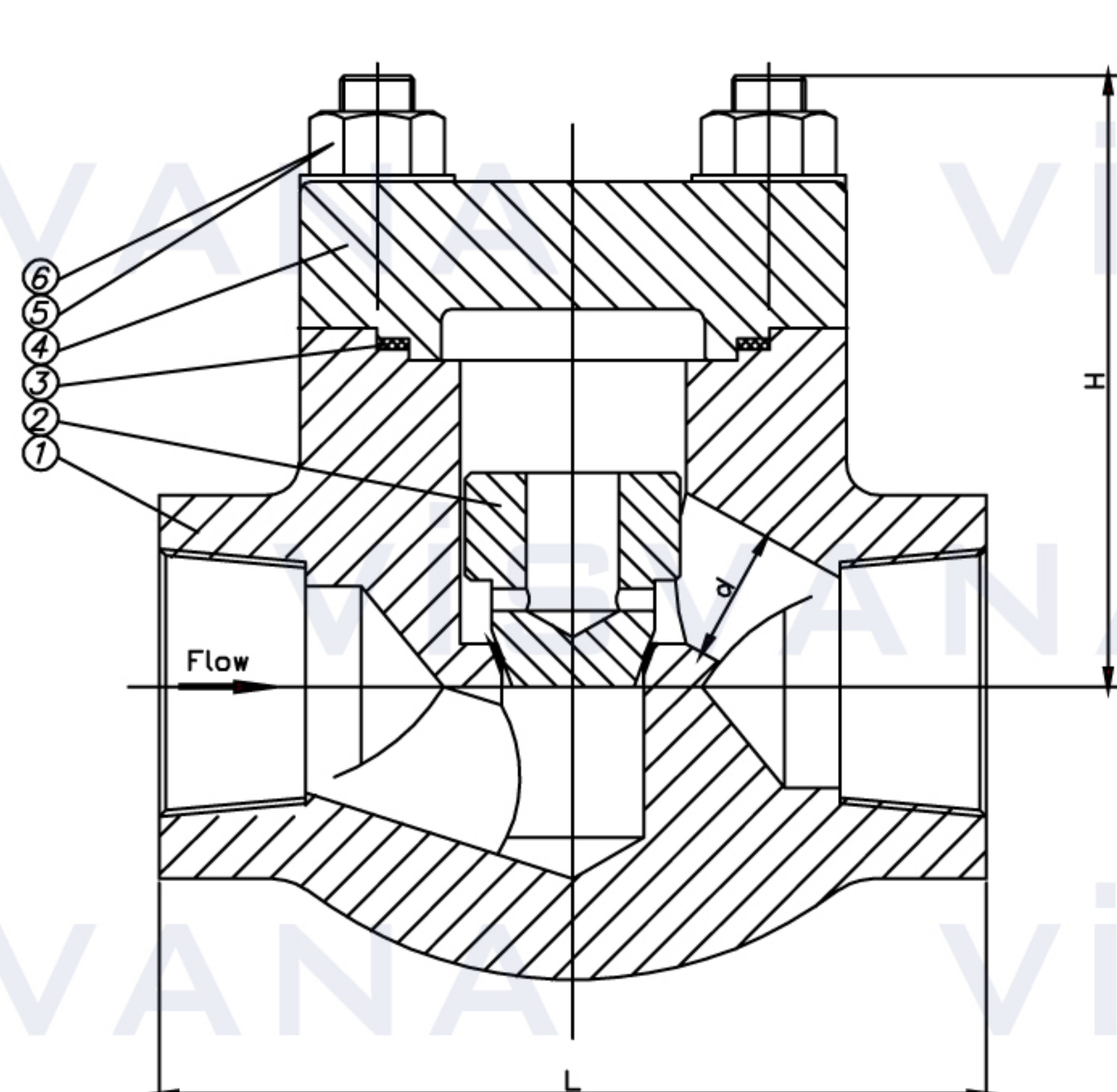

Swing Check Valve

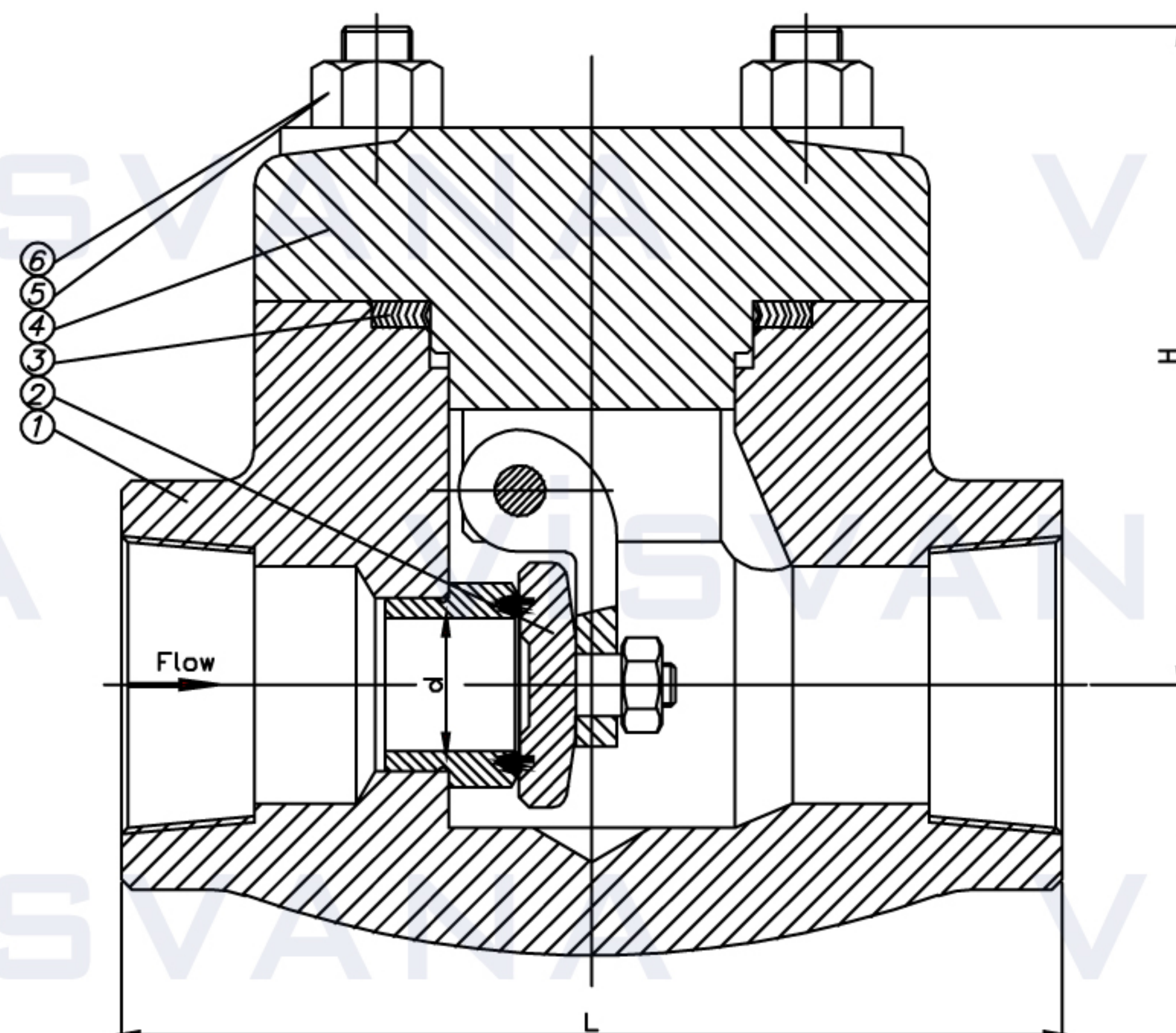

Lift Check Valve

PARTS AND MATERIAL LIST

Part Name	Material			
1	Body	ASTM A105	ASTM A182 F304	ASTM A182 F316
2	Disc	ASTM A105	ASTM A182 F304	ASTM A182 F316
3	Gasket	Graphite+SS304	Graphite+SS316	Graphite+SS316
4	Bonnet	ASTM A105	ASTM A182 F304	ASTM A182 F316
5	Bolt	A193 B7	A193 B8	A193 B8
6	Nut	A194 2H	A194 8	A194 8

Standards

Design and Manufacture	API 602.
Inspection and Test	API 598.
Socket-weld dimension	ASME B16.11.
End Threads dimension	ASME B1.20.1.
Pressure-temperature ratings	ASME B16.34.

Class	Size		Piston Check Valve					Swing Check Valve				
	NPS	DN	Dimensions (mm)			NPT	Weight (Kg)	Dimensions (mm)			NPT	Weight (Kg)
			L	d	H			L	d	H		
150-800	1/2"	15	79	10	54.5	1/2"	1.4	79	13	54.5	1/2"	1.3
	3/4"	20	92	13	54.5	3/4"	1.9	92	13	54.5	3/4"	1.7
	1"	25	111	17.5	72	1"	2.6	111	18	72	1"	2.4
	1 1/4"	32	120	23	81	1 1/4"	4.2	120	24	81	1 1/4"	4.0
	1 1/2"	40	152	28.5	94	1 1/2"	5.3	120	29	94	1 1/2"	5.1
	2"	50	172	35	112	2"	9.0	140	36.8	112	2"	8.8
900-1500	1/2"	15	92	10	73	1/2"	2.4	92	13	73	1/2"	2.2
	3/4"	20	111	13	73	3/4"	2.9	111	13	73	3/4"	2.7
	1"	25	120	17.5	84	1"	4.6	120	18	84	1"	4.4
	1 1/4"	32	152	23	97	1 1/4"	6.5	120	24	97	1 1/4"	6.3
	1 1/2"	40	172	28.5	115	1 1/2"	10.5	140	29	115	1 1/2"	10.3
	2"	50	220	35	132	2"	15.5	160	36.8	132	2"	15.3
2500	1/2"	15	150	11	102	1/2"	7.8					
	3/4"	20	150	14	102	3/4"	8.5					
	1"	25	170	19	107	1"	12.0					
	1 1/4"	32	200	25	128	1 1/4"	18.2					
	1 1/2"	40	200	28	128	1 1/2"	19.5					
	2"	50	250	35	143	2"	27.0					