

API SLEEVE TYPE SOFT SEALING PLUG VALVE

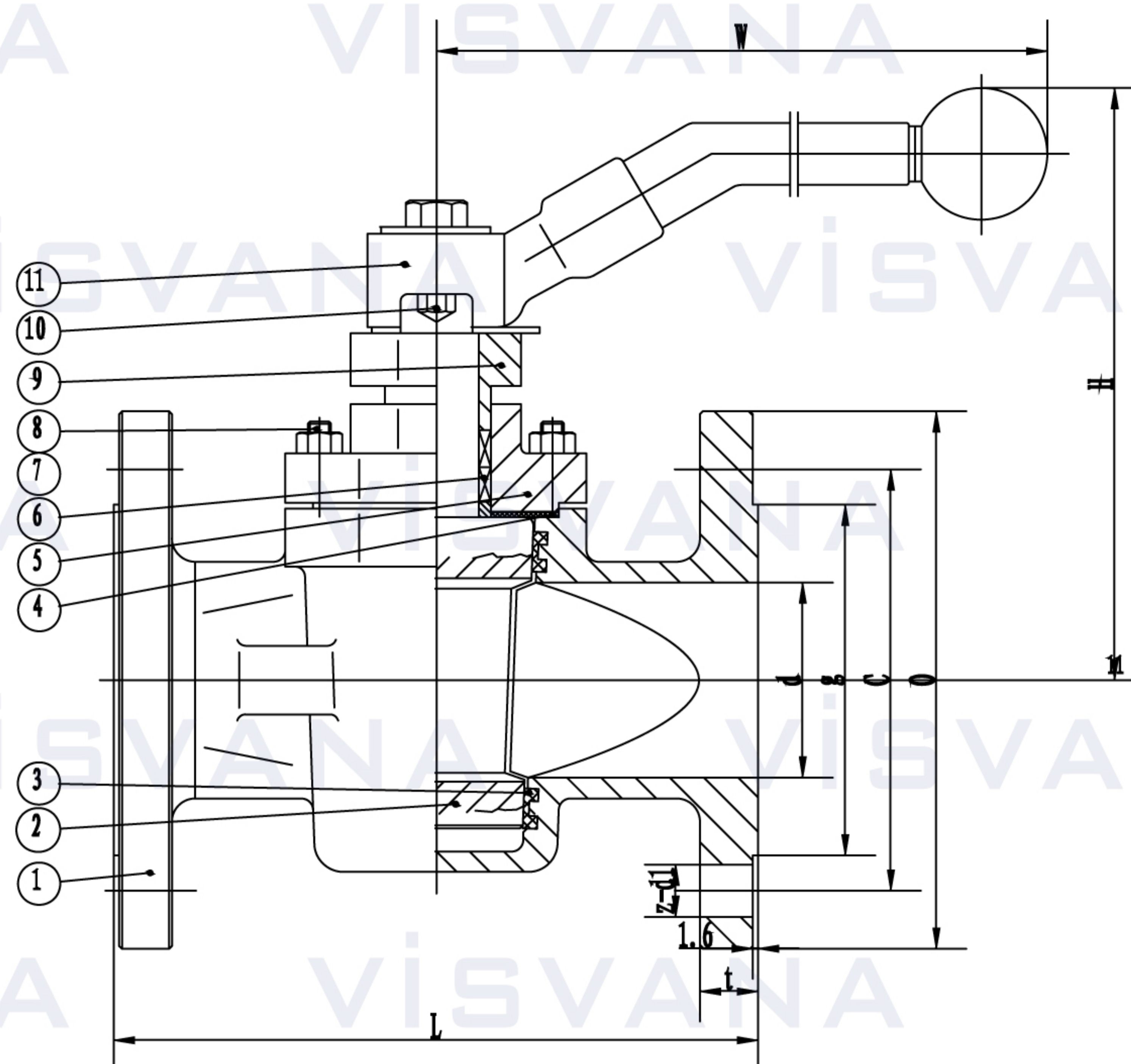

Standards

Design standard	API 599, API 6D
Face to face	ASME B16.10, API 6D
Butt welding end	ASME B16.25
End flange	ASME B16.5
Test and Inspection	API 598

Parts and material list

Parts name		Carbon steel to ASTM		Alloy Steel to ASTM				Stainless Steel to ASTM			
		A216 WCB	A352 LCB	A217 WCI	A217 WC6	A217 WC9	A217 C5	A351 CF8	A351 CF8M	A351 CF3	A351 CF3M
1	Body	A216 WCB	A352 LCB	A217 WCI	A217 WC6	A217 WC9	A217 C5	A351 CF8	A351 CF8M	A351 CF3	A351 CF3M
2	Sleeve	PTFE									
3	Plug	A182 F6a	A182 F6a	A182 F6a	A182 F6a	A182 F6a	A182 F6a	A182 F304	A182 F316	A182 F304L	A182 F316L
4	Cover	A216 WCB	A352 LCB	A217 WCI	A217 WC6	A217 WC9	A217 C5	A351 CF8	A351 CF8M	A351 CF3	A351 CF3M
5	Gasket	Flexible Graphite+SS, PTFE									
6	Adjusting gasket	A182 F6a	A182 F6a	A182 F6a	A182 F6a	A182 F6a	A182 F6a	A182 F304	A182 F316	A182 F304L	A182 F316L
7	Adjusting bolt	A193 B7	A320 L7	A193 B7	A193 B16	A193 B16	A193 B16	A193 B8	A193 B8	A193 B8	A193 B8
8	Bolt	A193 B7	A320 L7	A193 B7	A193 B16	A193 B16	A193 B16	A193 B8	A193 B8	A193 B8	A193 B8
9	Nut	A194 2H	A194 4	A194 2H	A194 4	A194 4	A194 4	A194 8	A194 8	A194 8	A194 8
10	Yoke	A216 WCB	A216 WCB	A216 WCB	A216 WCB	A216 WCB	A216 WCB	A216 WCB	A351 CF8	A351 CF8	A351 CF8
11	Worm	Cast iron or Carbon Steel									

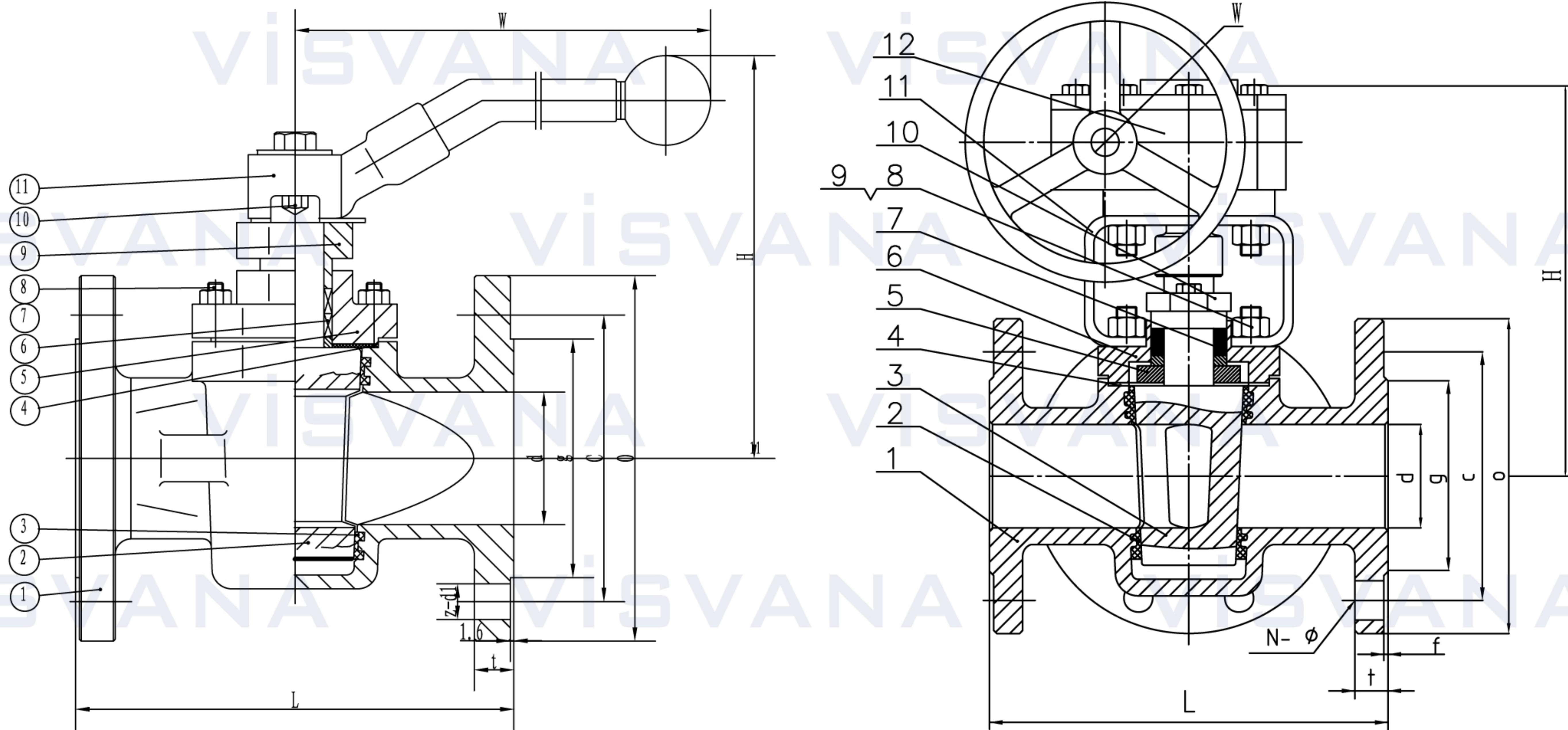

Class 150 & Class 300 Sleeve Soft Sealing Plug Valve

Size		Class 150					Class 300				
NPS	DN	Dimensions (mm)				Wt(Kg) W.H	Dimensions (mm)				Wt(Kg) W.H
		L	d	H	Do		L	d	H	Do	
1/2	15	108	13	110	175	8,5	140	13	110	175	9,5
3/4	20	117	19	115	175	9,5	152	19	115	175	10,5
1	25	127	25	115	175	10,5	165	25	115	175	12
1 1/4	32	140	32	135	220	12	178	32	135	220	14
1 1/2	40	165	38	140	280	14	190	38	140	280	16
2	50	178	49	150	305	18	216	49	150	305	20
2 1/2	65	190	62	165	350	22	241	62	165	350	24
3	80	203	74	180	405	26	283	74	180	405	29
4	100	229	100	380	300	40	305	100	380	300	53
5	125	254	127	460	300	60	381	127	460	300	75
6	150	267	150	520	320	70	403	150	520	320	85
8	200	292	201	580	320	130	419	201	580	320	185
10	250	330	252	620	350	219	457	252	620	350	230
13	300	356	303	680	380	381	502	303	680	380	390
14	350	381	334	760	450	570	762	334	760	450	550