

Design / Dizayn: EN 1171

Face to Face / L Boyu: EN 558

Serie 15 (DN3202 F5)

Pressure Rate / Basınç Aralığı: PN10-16-25-40

Size Range / Ölçü Aralığı: DN40-DN1000

Temperature / Sıcaklık: -20...+400 °C

Flange Ends / Flanş: DIN EN 1092-2/B

Test: EN 12266



Cast Steel / Çelik Döküm

GSC25

DN40-DN600 PN40

DN700-DN1000 PN 40

Pressure Range Basınç Aralığı	Cast Iron Pik Döküm GG25	Ductile Iron Sfero Döküm GGG40
DN40-DN600	PN16	PN25
DN700-DN1000	PN10	PN16

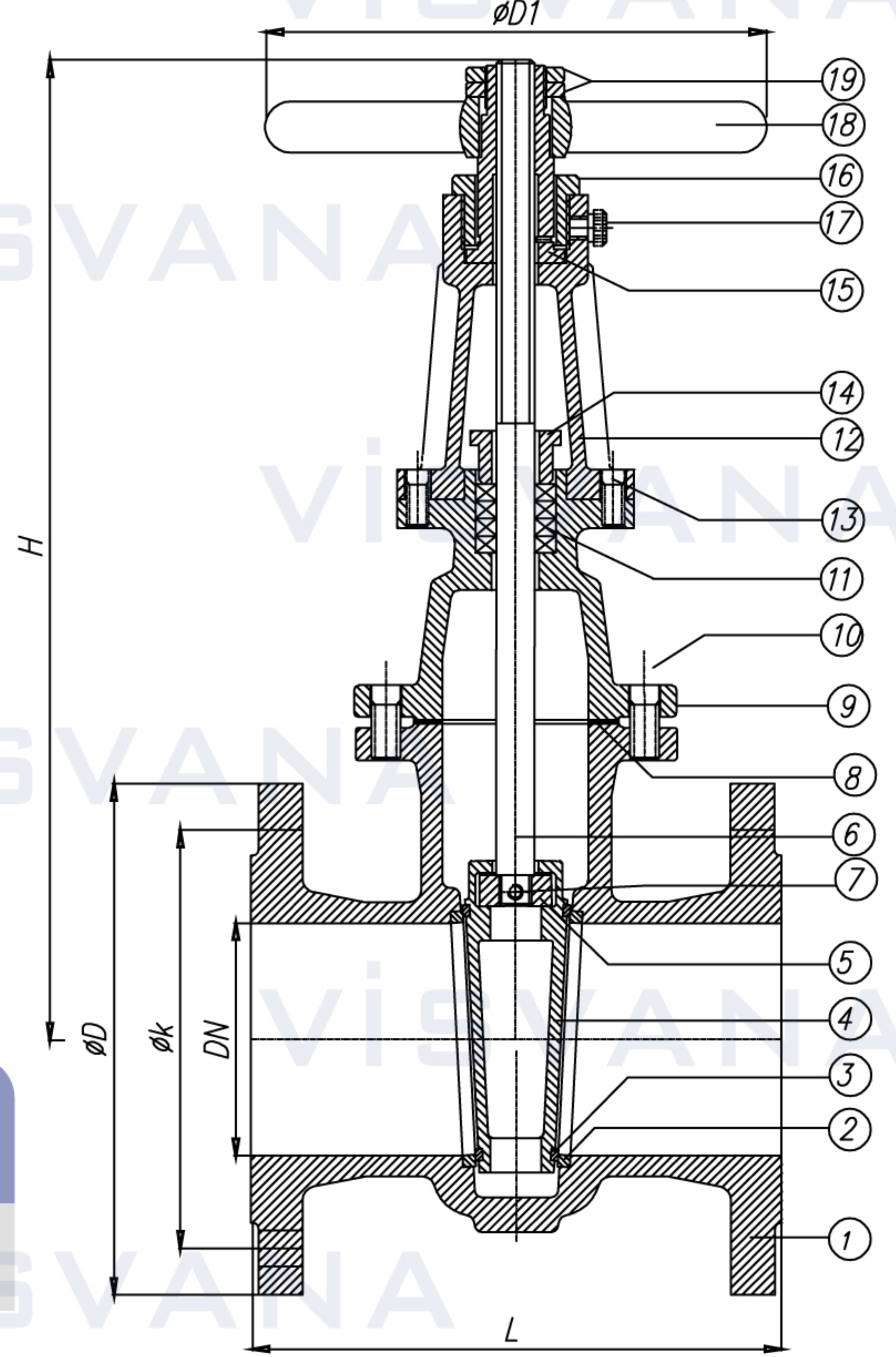

NO	PART NAME	PARÇA ADI	MATERIAL / MALZEME	NO	PART NAME	PARÇA ADI	MATERIAL / MALZEME
1	Body	Gövde	GG 25 / GGG-40 / GGG40.3 / GSC25 / Bronze RG5, RG7, RG10/ SS304, SS316	10	Bolt	Civata	8.8 / A2 / A4
2	Body seat	Gövde Burcu	Ms 58/ Bronze / S.S	11	Packing	Salmastra	GRAPHITE/ TEFLON
3	Wedge	Sürgü	GG 25 / GGG-40 / GGG40.3 / GSC25 / Bronze RG5, RG7, RG10/ SS304, SS316	12	Yoke	Boyunduruk	GG 25 / GGG-40 / GGG40.3 / GSC25 / Bronze RG5, RG7, RG10/ SS304, SS316
4	Wedge seat	Sürgü Burcu	Ms 58/ Bronze / S.S	13	Packing Nut	Salmastra Baskısı	GG 25 / GGG-40 / GGG40.3 / GSC25 / Bronze RG5, RG7, RG10/ SS304, SS316
5	Stem nut	Sürgü Somunu	Ms 58 /Bronze / S.S	14	Yoke Nut	Mil Yatağı	Ms 58/ Bronze / GGG 40
6	Stem	Mil	SS420/Ms58/Som59/CuZn35Ni/CuSn8, CuSn10/SS304,SS316	15	Centering Nut	Mil Yatağı Somunu	Ms 58/ Bronze / S.S
7	Pin	Sabitleme Pimi	Ms 58/ Bronze / S.S	16	Oil Nipple	Gresörlük	St.
8	Gasket	Conta	KLINGERITE/ EPDM/ GRAPHITE	17	Handwheel	Volan	GG 20
9	Bonnet	Kapak	GG 25 / GGG-40 / GGG40.3 / GSC25 / Bronze RG5, RG7, RG10/ SS304, SS316	18	Handwheel Nut	Volan Somunu	Ms 58 /Bronze / S.S

Nominal Pressure / Anma Basıncı	PN	10 - 16 - 25 - 40													
Nominal Diameter / Anma Çapı	DN	40	50	65	80	100	125	150	200	250	300	350	400	500	600
Valve Dimensions / Vana Boyutları TS EN 1171 DIN 3352/3-F5	L	240	250	270	280	300	325	350	400	450	500	550	600	700	800
	H min	365	380	450	470	580	650	725	815	1135	1220	1320	1530	1915	2070
	H max	425	450	540	560	690	790	895	1030	1430	1545	1700	1970	2465	2720
Flange Dimensions / Flanş Ölçüleri EN 1092 PN 10	D1	200		250		315		400		500		630		800	
	D	150	165	185	200	220	250	285	340	395	445	505	565	670	780
Flange Dimensions / Flanş Ölçüleri EN 1092-2 PN 16	k	110	125	145	160	180	210	240	295	350	400	460	515	620	725
	D	150	165	185	200	220	250	285	340	405	460	520	580	715	840
Weight / Ağırlık	k	110	125	145	160	180	210	240	295	355	410	470	525	650	770
	kg	19	21,5	30	34,5	46	57	71	148	205	285	380	535	860	1160

Not: Tabloda yer olmadığından PN 25 ve PN 40 flanş ölçülerine teknik bilgiler kısmındaki flanş ölçülerinden bakabilirsiniz.